

Installation guide

Overview: This guide will facilitate the installation of the Composite Wall Mount Audio/Video Module (listed below). Also discussed are cable handling guidelines.

Product: **Composite Wall Mount Audio/Video Module**
part number: **VAA-FS2AG-EW (Electric White)**
VAA-FS2AG-EI (Electric Ivory)

Tools you'll need: UTP Termination Tool, Wire Cutters

READ ALL INSTRUCTIONS

Cable Handling Guidelines

- Do not route audio/video cables through the same cable holes as the AC power cables.
- For safety, all audio/video cables should be separated from parallel AC power lines by at least 6 inches whenever possible.
- Avoid kinking the cable.
- Do not attach cable tie-downs too tightly. The cable fastening hardware should not compress the cable sheath.
- Do not bend the cable sharply. Be especially careful to dress the cables properly after passing them through a hole as the edges of the hole can compress or even damage the cable sheath.
- Follow all warnings on the products.
- For your safety, do not use this or any electrical product near water (unless specifically designed for wet areas).
- Do not install wiring during thunder and lightning storms.
- Use caution when handling or installing any computer, telephone, video, or electrical devices.



UNICOM's **5 Year Product Warranty** will warrant that all UNICOM products* will be free from defects in material and workmanship for a period of 5 years from the original date of purchase.

*Excludes all UNICOM testers and Industrial Switches.

See www.unicomlink.com for more information

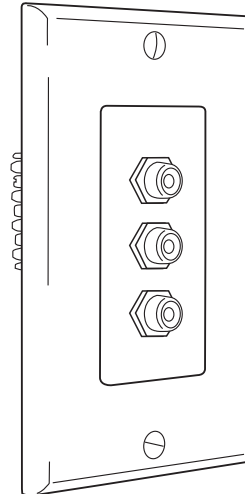

Specifications:

- Interface:** Video: One RCA female connector (gold)
Audio: Two RCA jacks for Left and Right Audio (gold plated)
UTP: 110-type rear punchdown input
- Impedance:** Video: 75 ohm Unbalanced
Audio: 600 ohm Unbalanced
UTP: 100 ohm balanced
- Bandwidth:** Video: DC~12 MHz
Audio: 50 Hz~15 KHz
- Distance:** Black & White Video, Color Video, and Audio:
Up to 100m. on Category 5e UTP cable
- Colors:** Electric White and Electric Ivory
- 110-type:** Pair 1: *-No Connection-*
Pair 2: Audio (right) signal
Pair 3: Audio (left) signal
Pair 4: Composite Video (V)

Unicom's Composite Wall Mount Audio/Video Module is a logical step in the evolution of home theater and residential audio/video components. This module will provide crystal clear sound and pictures over long distances utilizing economical Category 5e or higher UTP cable. Follow the simple instructions below to start enjoying your quality Unicom product.

Installation Instructions

- 1) Strip off approximately 2" of the Category 5e cable jacket, using the appropriate cable stripping tool.
- 2) Separate the pairs according to color (Blue-White/Blue, Orange-White/Orange, Green-White/Green, and Brown-White/Brown).
- 3) To terminate, place each wire into the insulation displacement contacts (IDC) by matching the wire color with the applicable colors on the punchdown block (see fig. 1).

TIP: We recommend untwisting the pairs no more than 1" from termination point.
- 4) If using a 110-type punchdown tool (*p/n: TLP-P110*), place the tool over each wire with the cutting blade facing outside of the IDC and punch down firmly.
- 5) Repeat this process with each pair.
- 6) Install included termination caps firmly onto the IDC.
- 7) Fasten insert and wallplate to electrical box using supplied screws.

That's it! Now you've made all of the necessary connections. Enjoy your Unicom Composite Wall Mount Audio/Video Module.

Composite Wall Mount Audio/Video Module

Side view (fig. 1)

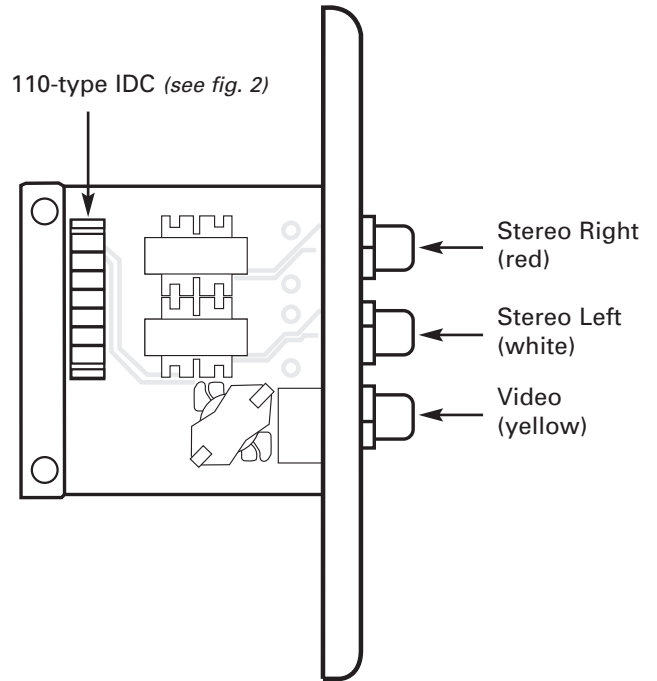

Composite Video and Audio IDC Pin-out (fig. 2)

